

ITEM NO.	PART NUMBER	DESCRIPTION	ADDDE HARDWARE/QTY.
1	RM5239	ESS3 TRAILER MOUNT WELDMENT	1
2	RM5212	LOWER HANDRAIL TUBE	1
3	RM5238	ESS3 STEP WELDMENT	1
4	RM5210	HANDRAIL CHANNEL BRKT.	2
5	RM5211	TOP HANDRAIL TUBE	1
6	RM5236	TOP MOUNTING BRKT.	1
7	Screw, Machine, Phillips, Rounded Head, .375-16 x .750 Long	PHILLIP SCREWS	8
8	CAP SCREW, HEX HEAD	3/8-16 X .75 LONG	2
9	RM5217	U-CLAMP BRKT. PAINTED	1
10	CAP SCREW, HEX HEAD	3/8-16 X 2.50 LONG	2
11	FLAT WASHER	3/8" FLAT WASHER	2
12	Nut, Hex, Lock, Nylon, .375-16	3/18-16 NUT	2

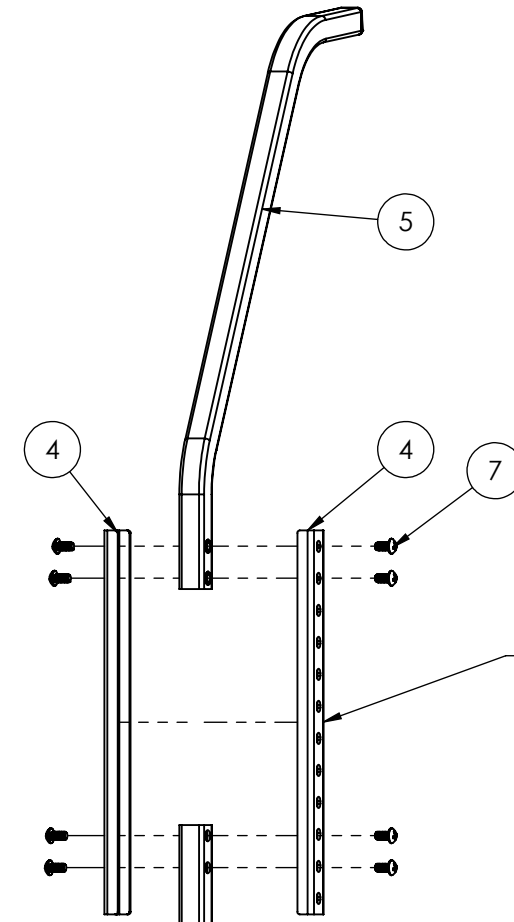

MOUNT **ITEM 5** WITH **ITEM 2** USING **ITEM 4** TO DESIRED HEIGHT.

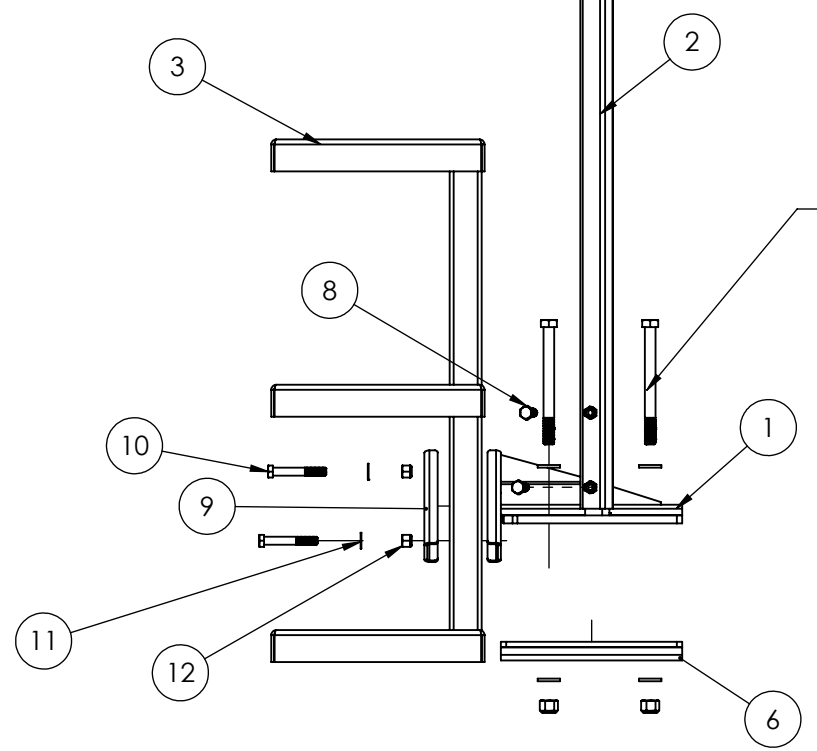
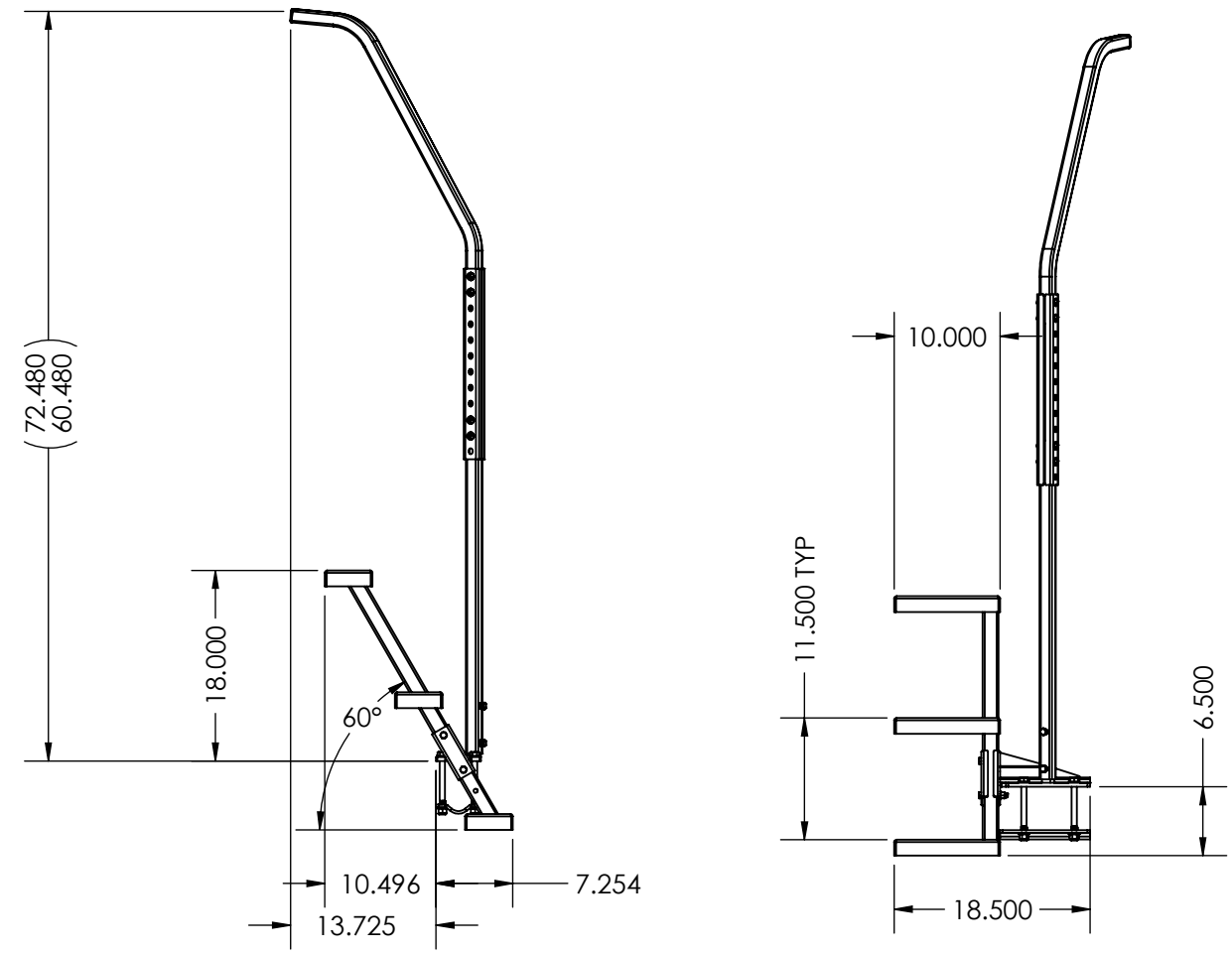

CUSTOMER PROVIDED HARDWARE

PROPRIETARY AND CONFIDENTIAL
THE INFORMATION CONTAINED IN THIS DRAWING IS THE SOLE PROPERTY OF REGAL MACHINE MFG. ANY REPRODUCTION IN PART OR AS A WHOLE WITHOUT THE WRITTEN PERMISSION OF REGAL MACHINE MFG. IS PROHIBITED.

REGAL MACHINE MFG.

TITLE: **ESS3**

SIZE: B	DWG. NO: ESS3 CUSTOMER ASSEMBLY	REV: NR
SCALE: 1:9	WEIGHT: LBS	SHEET 1 OF 2

ESS3 ASSEMBLY

MOUNTING HARDWARE (NOT INCLUDED): may be purchased at local hardware store.

- ½-13 Zinc coated bolts. Length is to be 2.00" longer than the depth of the mounting surface. (QTY. 4)
- ½" Flat washers (QTY. 8)
- ½-13 Nylon locking nuts (QTY. 4)

HANDRAIL ASSEMBLY

- The lower and upper handrails are held together by two split collars with 3/8" holes drilled in them. These holes are spaced 1.5" for a total adjustment of 12" up or down.
- Use the phillips head screws (QTY. 8) for the top and bottom hand rail. 4 screws on top, 4 screws on bottom.
- Adjust the handrail to a height that works best for you. The height can be adjusted from 60"-72"
- Once handrail is adjusted to the desired height, place it over the 7/8" x 7/8" x 7" bar stock on the top bracket assembly and tighten using the 2 set screws.

ATTACHING BRACKETS TO TONGUE

- Secure the top and bottom brackets to the tongue/frame with the ½" bolts, flat washers, and nylon nuts (NOT INCLUDED)

ATTACHING STEPS TO BRACKET

- Secure the step weldment (1.25" tubing) to the top bracket using the u-clamp bracket and the 3/8" bolts and locking nuts (QTY 2).
- These steps are adjustable 2" up or down to suit your preference.

LOCTITE

- We recommend applying mid-grade Loctite to all connections. This will help prevent screws and bolts from coming loose while traveling.

IF FURTHER ASSISTANCE IS NEEDED, PLEASE CONTACT OUR OFFICE.

Email: info@easystem.com

Phone: 800-966-1502