

ITEM NO.	PART NUMBER	DESCRIPTION	Assembled/QTY.
1	RM5390	BASE WELDMENT	1
2	MSTB11G-1.25-240-P&O (0002)	LOWER HANDRAIL	1
3	RM5238	ESS3 STEP WELDMENT	1
4	RM5210	HANDRAIL CHANNEL BRKT.	2
5	MSTB11G-1.25-240-P&O (0001)		1
6	Screw, Machine, Phillips, Rounded Head, .375-16 x .750 Long	PHILLIP SCREWS	8
7	RM5217	U-CLAMP BRKT. PAINTED	1
8	CAP SCREW, HEX HEAD	3/8-16 X .75 LONG	2
9	CAP SCREW, HEX HEAD	3/8-16 X 2.50 LONG	2
10	WASHER, FLAT, ZINC, ID .531, OD 1.062	NOT PROVIDED	2
11	Nut, Hex, Lock, Nylon, .375-16	3/18-16 NUT	2
12	Hex weld nut	HW 3/8 -16	2

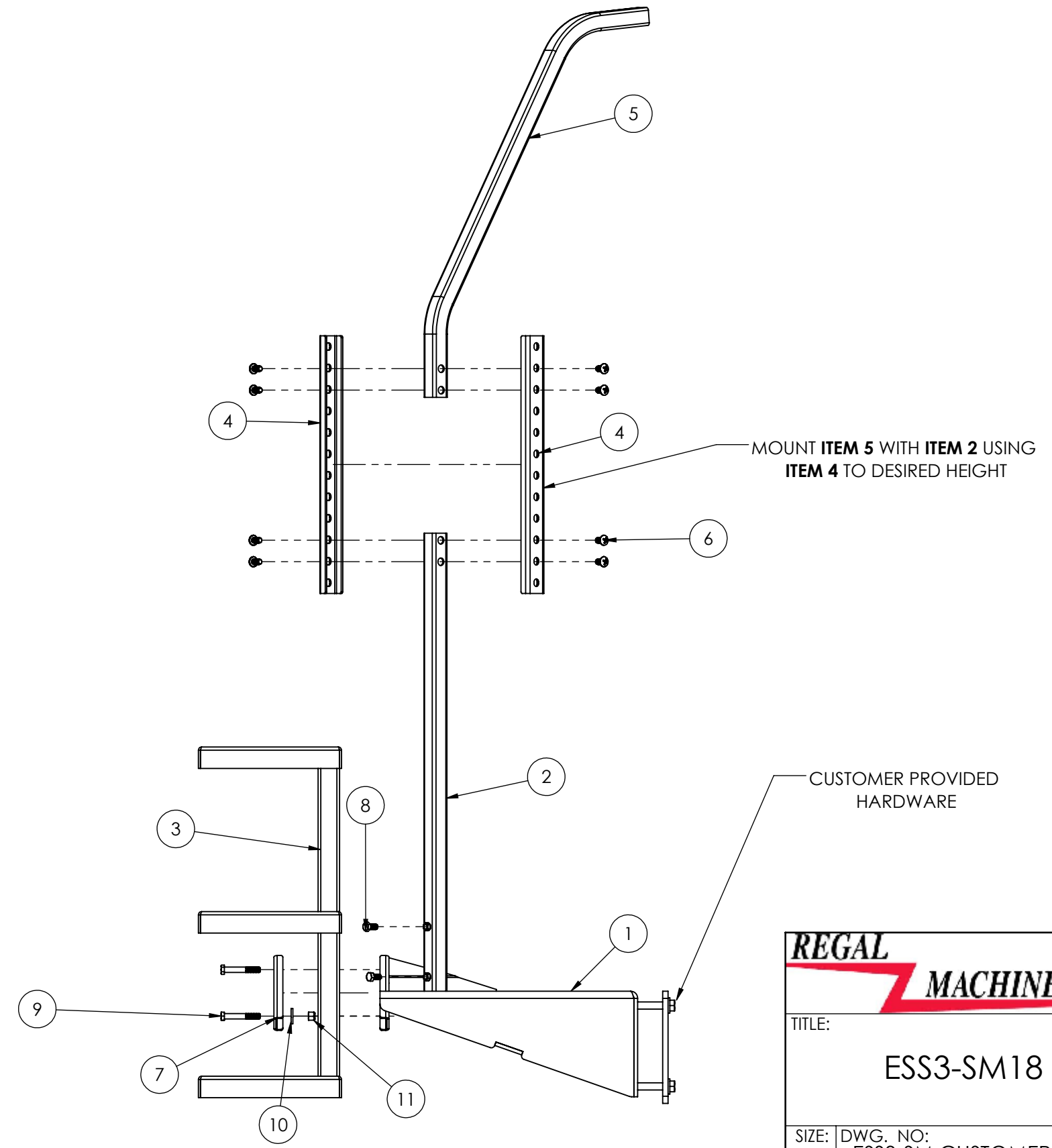
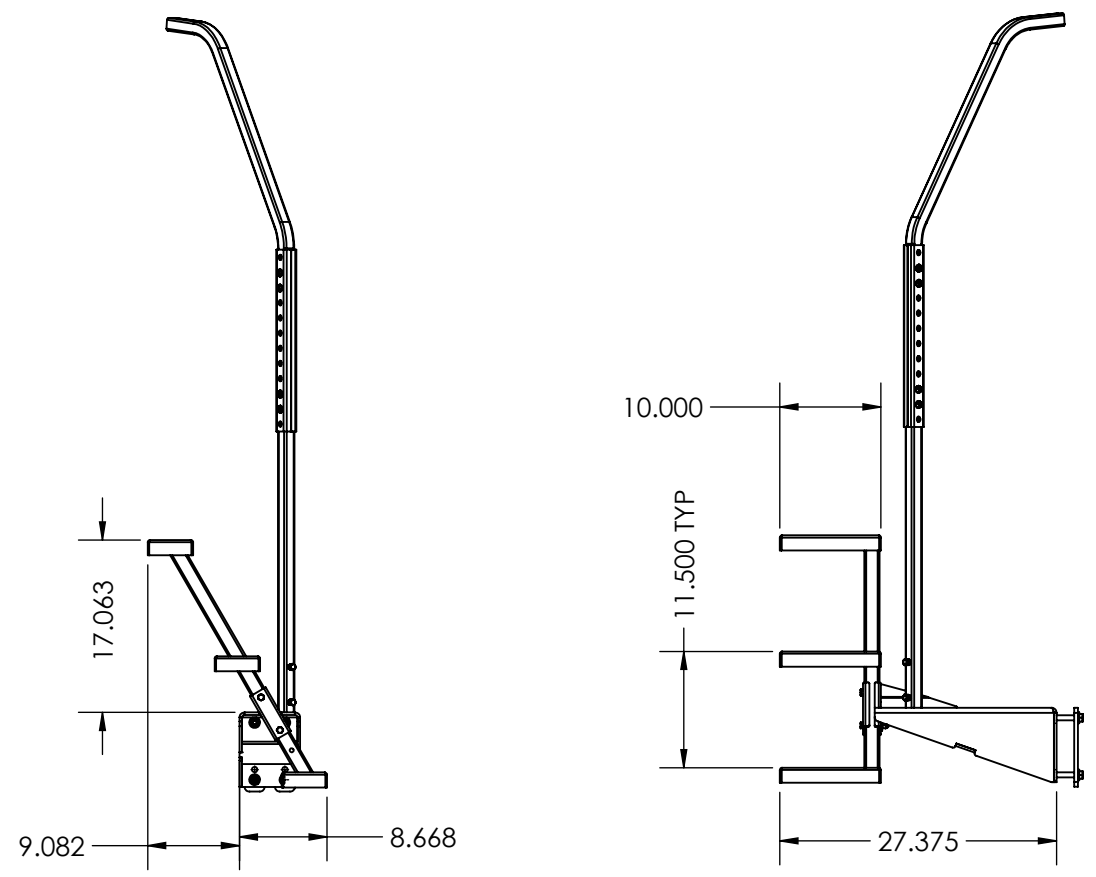

**REGAL**  
**MACHINE MFG.**

TITLE:  
**ESS3-SM18**

SIZE: <b>B</b>	DWG. NO: ESS3-SM CUSTOMER ASSEMBLY	REV: NR
SCALE: 1:9		WEIGHT: LBS
		SHEET 1 OF 2

## ESS3-SM ASSEMBLY

### MOUNTING HARDWARE (INCLUDED):

- ½ - 13 x 4" zinc coated bolts (QTY. 4).
- ½" flat washers (QTY. 8)
- ½ - 13 nylon locking nuts (QTY. 4)

### HANDRAIL ASSEMBLY

- The lower and upper handrails are held together by two split collars with 3/8" holes drilled in them. These holes are spaced 1.5" for a total adjustment of 12" up or down.
- Use the phillips head screws (QTY. 8) for the top and bottom hand rail. 4 screws on top, 4 screws on bottom.
- Adjust the handrail to a height that works best for you. The height can be adjusted from 60"-72".
- Once handrail is adjusted to the desired height, place it over the 7/8" x 7/8" x 7" bar stock on the top bracket assembly and tighten using the 2 set screws.

### ATTACHING SIDE MOUNT BRACKETS TO FRAME

- Secure the side mount bracket to the frame using the ½" bolts, flat washers and nylon nuts.

### ATTACHING STEPS TO SIDE MOUNT BRACKET

- Secure the step weldment (1.25" tubing) to the top bracket using the u-clamp bracket and the 3/8" bolts and locking nuts (QTY 2).
- These steps are adjustable 2" up or down to suit your preference.

### LOCTITE

- We recommend applying mid-grade Loctite to all connections. This will help prevent screws and bolts from coming loose while traveling.

**IF FURTHER ASSISTANCE IS NEEDED, PLEASE CONTACT OUR OFFICE.**

Email: [info@easystepsystem.com](mailto:info@easystepsystem.com) <<mailto:info@easystepsystem.com>>

Phone: 800-966-1502